



AIRCRAFT CUSTOM RESTRAINT ORDER FORM

PLEASE CHECK APPROPRIATE BOXES **PRINT, SCAN & EMAIL.**

SEND TO: info@crowssafety.com. WE ACKNOWLEDGE ALL EMAILS.

4114 N. Pecos Rd. Suite 101, North Las Vegas, NV 89115 • 725-726-7432

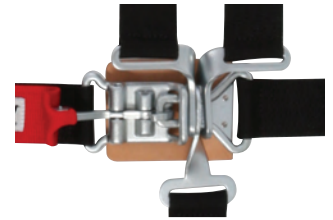

Note:
See worksheet
on back

Kam lock with 2" Lap Belt Adjusters
Built into Kam tangs. Starting at \$167⁰⁰
(Pull down adjustment ONLY)

Standard Kam Lock
Starting at \$132⁰⁰
(Pull up adjustment)

Latch & Link
Starting at \$57⁰⁰
(Pull up adjustment)

LAP BELT

Lap Belt Mounting Hardware

Bolt-In hole diameter:

1/4" 5/16" 3/8" 7/16"

Lap Belt Length (Standard Length 52")

(Measurement is from end to end)

40" 52" 60"

Custom add \$12⁰⁰ Length: _____
(See worksheet on back)

Lap Belt Adjustment

Pull DOWN Pull UP Adjustment

HARNESS Custom Lengths add \$12⁰⁰

(See worksheet on back)

2" Individual Harness: \$55⁰⁰ Length: _____

2" Y-Harness: \$55⁰⁰ Length: _____

2" V-Harness: \$55⁰⁰ Length: _____

Harness Mounting

Wrap Around Bolt In*

*Choose Bolt-In hole diameter:

1/4" 5/16" 3/8" 7/16"

Aircraft type: _____ Quantity: _____

Comments: _____

CONTACT/BILLING INFORMATION

Name: _____

Address: _____

City: _____ State: _____ ZIP: _____

Phone number where you may be reached between 8am - 4pm PST: _____

e-mail: _____

Visa MC Discover CVS 3-digit code #: _____

Credit card #: _____ \ _____ \ _____ \ _____ Exp. _____

WEBBING COLOR (Samples available on request)

Red Blue Black Gray

OPTIONS

Harness Pads (Sewn On. NOTE:

Harnesses come with the same color pad as the webbing. You may choose a different color to compliment your installation, but they won't be returnable.)

2" \$36⁰⁰ (pair, same color as webbing)

Alternate Color (may not be returned)

Red Blue Black Gray

Aluminum Harness Adjusters

2" \$40⁰⁰ (pair)



Black Hardware

\$12⁰⁰ (set)



Anti-submarine Belt

2" \$18⁰⁰



Choose Bolt-In hole diameter:

1/4" 5/16" 3/8" 7/16"

CROW SAFETY GEAR WORKSHEET

All Models Experimental Aircraft

Name _____ Model _____

Choose your harness, indicate lengths:

Individual Harness

Y-Harness

V-Harness

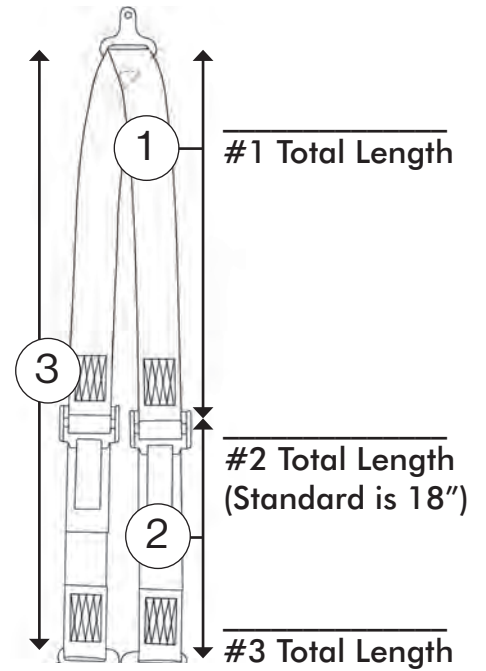
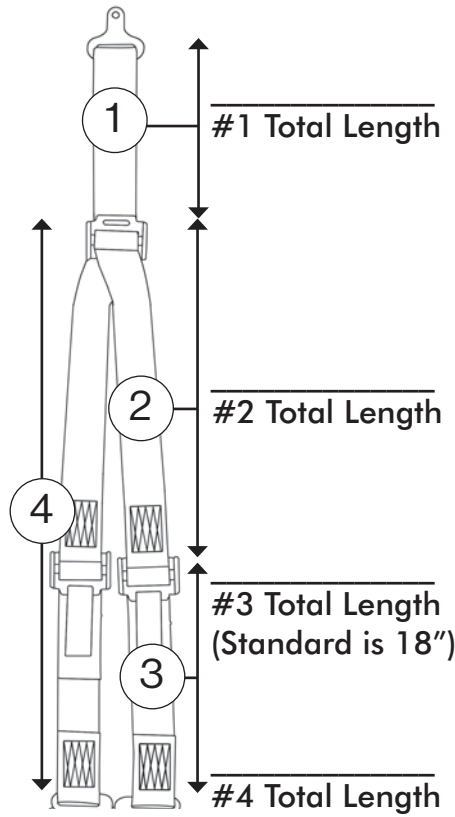
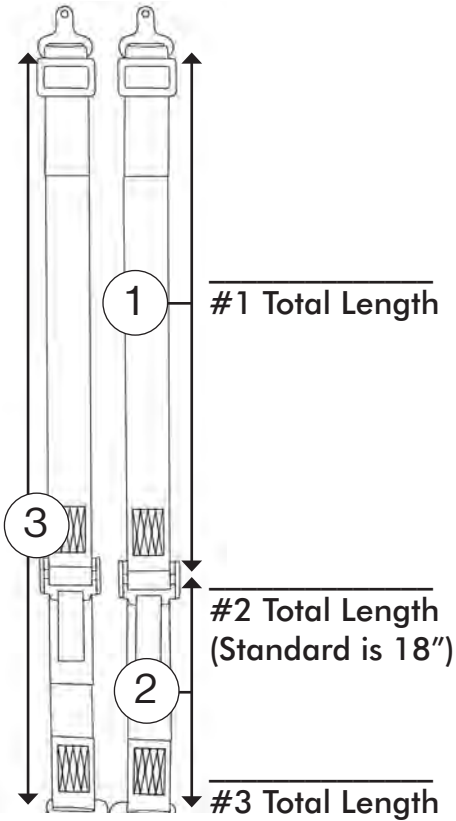

Lap Belt: Choose your adjustment: Pull-UP fill in #5 & 6 or Pull-DOWN fill in #9

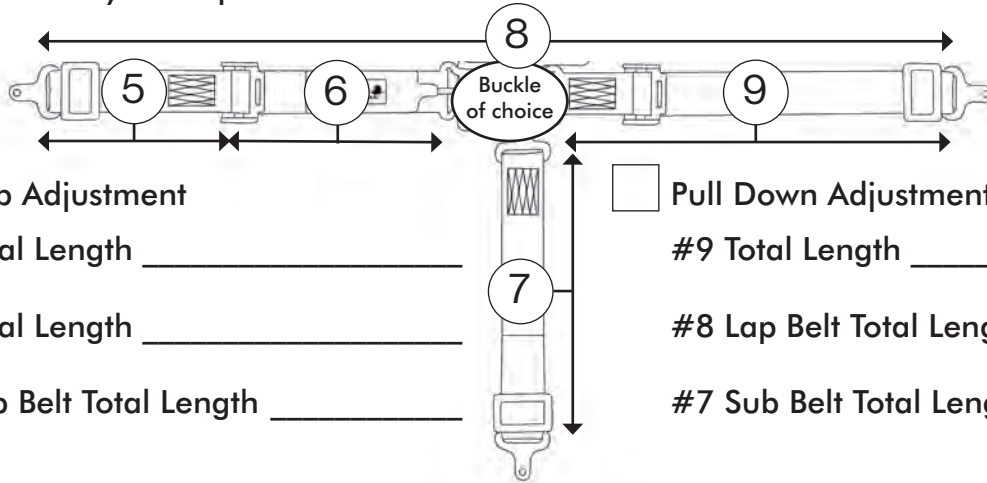

Pull Up Adjustment

Pull Down Adjustment

#5 Total Length _____

#9 Total Length _____

#6 Total Length _____

#8 Lap Belt Total Length _____

#8 Lap Belt Total Length _____

#7 Sub Belt Total Length _____

Notes: _____
